

ENGLISH

Thank you very much for purchasing a Sigma Lens. This lens is an Equisolidangle Projection type fisheye lens which provides a 180 degree angle of view in any direction against the film plane. In order to get the maximum performance and enjoyment out of your Sigma lens, please read this instruction booklet thoroughly before you start to use the lens.

DESCRIPTION OF THE PARTS (fig.1)

- | | |
|---------------------------------|---|
| ① Adapter Ring | ⑥ Filter Holder |
| ② Focus Ring | ⑦ Focus Mode Switch
(Sigma SA and Canon AF only) |
| ③ Distance Scale | ⑧ Mount |
| ④ Depth of Field Read Out Index | ⑨ Guide Plate |
| ⑤ Focus Index Line | |

NIKON AF TYPE CAMERAS

This Lens functions same as a G Type (type without Aperture) auto-focus Nikon lens. Depending on the combination with camera some restrictions with its functions may result. For more details, please refer to instruction manual of the camera in use etc.

PENTAX AF TYPE CAMERAS

This Lens functions same as a FAJ Type (type without Aperture) auto-focus Pentax lens. Depending on the combination with camera some restrictions with its functions may result. For more details, please refer to instruction manual of the camera in use etc.

ATTACHING TO CAMERA BODY

When this lens is attached to the camera body it will automatically function in the same way as your normal lens. Please refer to the instruction booklet for your camera body.

- On the lens mount surface, there are a number of couplers and electrical contacts. Please keep them clean to ensure proper connection. To avoid damaging the lens, be especially sure to place the lens with its front end down while changing the lens.
- When you take a picture, please remove the lens cap and the adapter ring not just the lens cap, to avoid vignetting. (fig.2)

SETTING THE EXPOSURE MODE

Evaluating Metering Systems which use the whole screen to determine exposure cannot be used with this Circular Image Fisheye Lens. Exposure can be determined only from the center of the captured scene. Therefore, Center-Weighted Metering, Partial Metering, and Spot Metering systems can properly sense the scene's exposure through the lens and therefore give an accurate exposure reading. However, Evaluating Metering Systems (Matrix Metering, Multi-Segment Metering, Honeycomb-Pattern Metering, etc.) cannot determine the correct exposure through the Circular Image Fisheye Lens. If your camera has only an Evaluative Metering System, please switch to manual exposure mode and/or use a hand held exposure meter.

FOCUSING

《Auto Focus》

When you use the AF lens with the AF camera body, Auto Focusing is possible. Select the autofocus mode on your camera body (set the focus mode switch on the lens to "AF" for Sigma SA and Canon AF lens). In the autofocus mode, your camera will set the focus automatically. While auto focusing, please do not touch the focus ring around the lens.

- To avoid damaging AF mechanism, please do not turn the focus ring manually while in the autofocus mode.
- This lens has a very deep depth of field, despite its short focal length. Although your lens performs precise autofocusing, this feature might cause the lens' distance scale to show a different reading than the real subject - to - lens distance.

《Manual Focus》

You can set the focus by turning the focus ring. When you focus manually with AF lens, select the manual focus mode on your camera body (set the focus mode switch on the lens to "M" for Sigma SA and Canon AF lens).

- The viewfinder of some Nikon AF cameras have indicators to display the focus status. The "•" symbol indicates that correct focus has been set, "▶" indicates that focus is set in front of the subject, and "◀" indicates that focus is set behind the subject. When this AF lens is used with Nikon AF cameras in MF mode, please adjust the lens' focus until the "•" symbol is visible.
- When operating this lens in manual focus mode, it is recommended that correct focus be confirmed visually in the viewfinder rather than relying on the distance scale. This is due to possible focus shift resulting from extreme changes in temperature which cause various components in the lens to expand and contract. Special allowance is made for this at the infinity setting.

PREVENTION OF FLARE AND GHOST

Because of the extremely wide angle of view of this lens, flare and ghosting may occur much more easily than with other lenses. When you take a picture with this lens, please pay special attention to flare and ghosting which can occur when shooting near or directly into the sun or other very bright lights.

DEPTH OF FIELD SCALE

The depth of field scale helps you to check the depth of field (the zone of sharpness) of your composition. For example in figure (3), the depth of field zone is shown when the aperture F5.6 is used.

INFRARED PHOTOGRAPHY

When photographing using infrared film and infrared filters an adjustment to focus must be made. First focus in the normal way. Then set focus switch to manual focus mode. Turn the focus ring manually so that the distance scale marking that was previously aligned with the focus index mark is now aligned with the infrared guide mark "R". (fig.4)

FILTER

Filters cannot be mounted on the front of the lens. If you wish to use filters, please use gelatin type. Please cut the gelatin filter, using the guide plate accessory as a pattern, and insert the filter into the filter holder at the rear of the lens. (fig.5)

BASIC CARE AND STORAGE

- Avoid any shocks or exposure to extreme high or low temperatures or to humidity.
- For extended storage, choose a cool and dry place, preferably with good ventilation. To avoid damage to the lens coating, keep away from mothballs or naphthalene gas.
- Do not use thinner, benzene or other organic cleaning agents to remove dirt or finger prints from the lens elements. Clean by using a soft, moistened lens cloth or lens tissue.
- This lens is not waterproof. When you use the lens in the rain or near water, keep it from getting wet. It is often impractical to repair the internal mechanism, lens elements and electric components damaged by water.
- Sudden temperature changes may cause condensation or fog to appear on the surface of the lens. When entering a warm room from the cold outdoors, it is advisable to keep the lens in the case until the temperature of the lens approaches room temperature.

TECHNICAL SPECIFICATIONS

Lens construction	6 - 11
Angle of View	180°
Minimum Aperture	22
Minimum Focusing Distance	0.135m (0.443ft)
Magnification	1:4.6
Filter Size	-
Dimensions Dia.×Length	73.5×68.6mm (2.89×2.7 in)
Weight	400g (14.1 oz)

Dimensions and weight include the SIGMA mount.



The CE Mark is a Directive conformity mark of the European Community (EC).

SIGMA (Deutschland) GmbH Carl-Zeiss-Str. 10/2, D-63322 Rödermark, F.R.GERMANY
Verkauf: 01805-90 90 85-0 Service: 01805-90 90 85-85 Fax: 01805-90 90 85-35

(1)

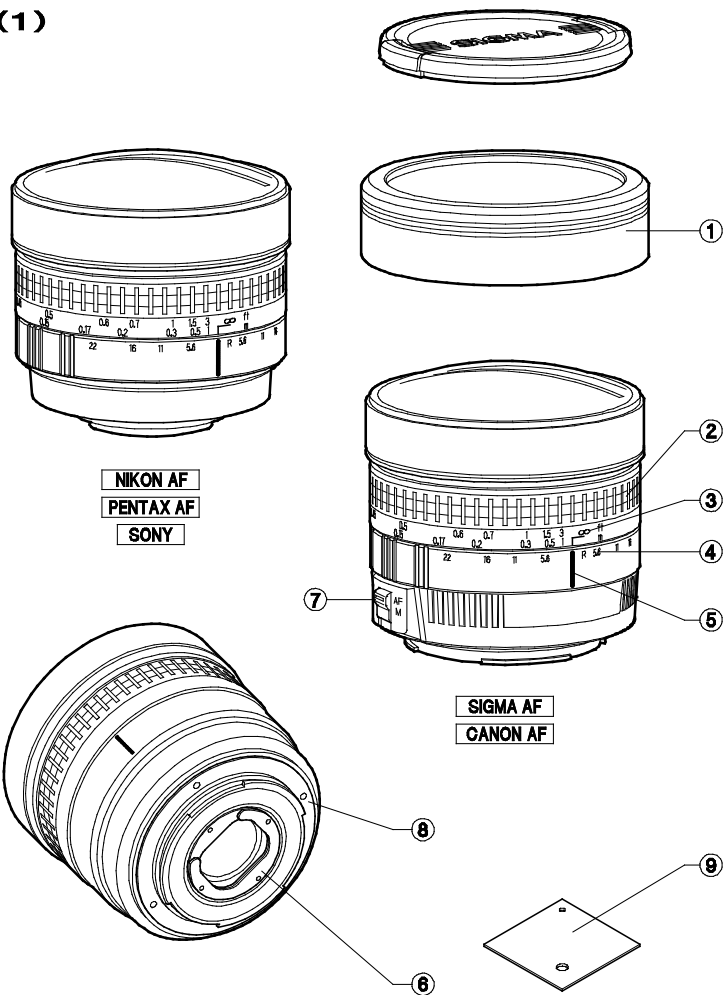

(2)

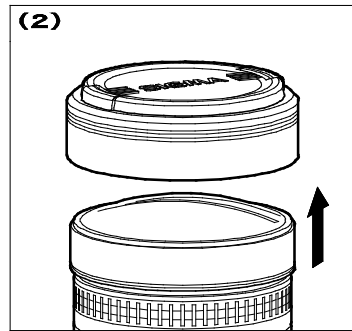

(3)

