

# KIRON



---

## **80-200mm f4.5 Macro Focusing Zoom**

**Instructions**

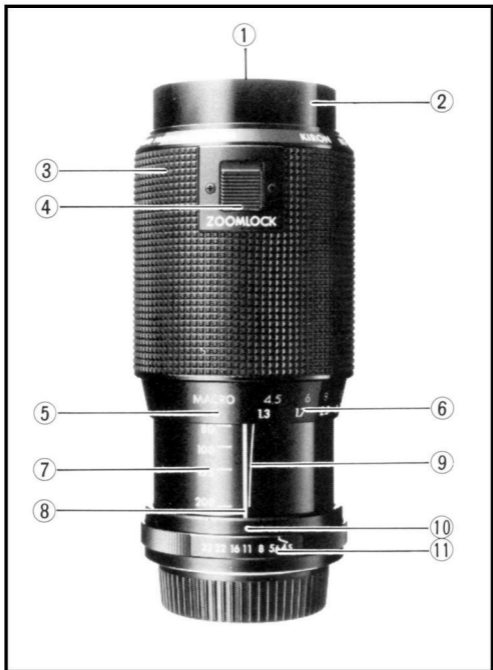

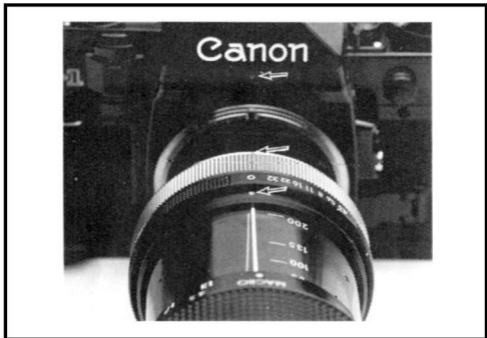

a

Your new Kiron 80-200mm f4.5 Macro Focusing Zoom is the product of advanced optical design and precision mechanical engineering. It's also easy to use. Simply take a few minutes to familiarize yourself with the following description of features and general instructions. With proper use and care, your Kiron 80-200mm f4.5 will provide you with years of outstanding service.

## Features

---

1. 55mm Filter Threads
2. Non-Rotating Front Barrel
3. Zoom/Focus Control
4. ZOOMLOCK™ Switch
5. Macro Focus Index Mark
6. Distance Scales
7. Focal Length Index Marks
8. Distance Index Line
9. Infrared Focus Line
10. Aperture Index Mark
11. Aperture Ring\*

\* Lens shown is Nikon mount. Canon, Minolta, Konica, Yashica/Contax mount lenses have aperture rings that turn in the opposite direction.

## Mounting the Lens

---

**Nikon, Pentax, Minolta, Olympus, Konica, Yashica/Contax mounts**—Use the standard procedure for mounting your camera brand lenses.

**Canon mount**—Canon mount Kiron lenses have a chromed mounting ring. Mount the lens as shown in photo A, with all three index marks aligned. Turn the mounting ring clockwise to lock the lens onto your camera.

## Exposure Settings

---

**Nikon, Pentax, Minolta, Olympus, Konica, Yashica/Contax mounts**—Use the same metering procedures you would use with your camera brand lenses.

**Canon mount**—Canon mount Kiron lenses have a slightly different aperture ring than Canon brand lenses. Canon brand lenses have a green “A” on the aperture ring for the various automatic exposure modes. Kiron lenses have a green “O”. The settings and functions are the same; only the marks are different.

## **Zooming and Focusing**

---

Twist the Zoom/Focus Control to focus; push or pull to zoom. You may find it easier to focus with the Zoom/Focus Control set at 200mm. You can then zoom to the image size you want, being careful not to change focus. (Note: The plane of focus for infrared radiation is different from that of light. When using infrared films you must therefore move the focus setting to the Infrared Focus Line.)

Also note that the front barrel (2) doesn't rotate as you zoom or focus. Very few zoom lenses have this feature. The non-rotating front barrel eliminates the inconvenience of having to reset a polarizing filter or other special-effect filters each time you change zoom or focus settings.

## **Macro Focusing**

---

For the maximum image magnification (1/4 life-size), set the Zoom/Focus Control to 200mm and turn it so that the orange Macro Focus Index Mark (5) aligns with the red Aperture Index Mark (10). Next, move toward your

subject until it's in focus. It should come into focus approximately 34 inches (86 cm) from the front lens element. If the image is too large, simply zoom to a shorter focal length. The image will stay in focus.

## **Using the ZOOMLOCK™ Mechanism**

---

This exclusive feature allows you to lock-in any focal length you choose so you can concentrate on focusing and bracing the lens. Move the ZOOMLOCK™ Switch back toward the camera to lock-in the desired focal length. Move it forward to unlock the zoom mechanism.

## **How to Get the Most From Your Lens**

---

The steadier your camera, the sharper the picture. Camera motion can blur your pictures just as easily as subject motion. Your minimum shutter speed for hand-held photography should therefore be no lower than 1/125 second. When using slower shutter speeds, take

care to properly brace yourself or place the camera on some form of steady support.

Choose your optical accessories with the same regard for quality you used when buying this lens. Low-quality filters, teleconverters, and extension tubes will compromise the high-quality results you expect from your Kiron 80-200mm f4.5.

## Lens Care

---

When using your lens, take normal care to protect the front element from fingerprints, dirt, sand, and water. Many photographers use a Skylight 1A or UV filter for this purpose. Remove dust with a soft lens brush or a gentle puff of compressed air. Remove fingerprints or other marks with *photographic* lens tissue moistened with *photographic* lens cleaner. Never rub the lens with dry tissue of any other material, since this can scratch the coatings.

When your lens isn't being used, store it in a cool, dry place with both front and rear lens caps attached. If you live in a humid climate, store the lens with the supplied package of silica gel.



# Specifications

---

Aperture Range: f4.5 - f32

Angles of Acceptance: 30.3° - 11.8°

Optical Construction: 11 elements, 8 groups

Maximum Reproduction Ratio: 1:4 at 200mm

Minimum Focusing Distance from Film Plane:

1.05 m (41 in.)

Length at Infinity Focus: 129 mm (5.03 in.)

Maximum Barrel Diameter: 67.5 mm (2.6 in.)

Accessory Size: 55mm

Weight: 616 g (22 oz.)

Weight and length may vary according to lens mount.  
Specifications subject to change without notice.

**Kiron Corporation**  
**Carson, CA 90746 USA**

Subsidiary of  
**Kino Precision Industries, Ltd.,**  
**Tokyo, Japan**

This pdf applies to lenses with serial numbers:  
x69xxxxx and x83xxxxx.

It was created for AllPhotoLenses by boggy in July 2013